



---

RPTR-OBA/734  
INSTALLATION MANUAL

REV: B (04/25/2022)

---



© Kleinn Air Horns 2021, All Rights Reserved

PO Box 91278 Tucson, AZ 85752

Phone: (520) 579-1531

Web: <https://www.kleinn.com>



## Table of Contents

1	Safety First .....	4
2	Application Chart .....	5
2.1	Bolt-On Vehicle List.....	5
2.2	Excluded Vehicles.....	5
2.3	Aftermarket Product Compatibility .....	5
3	Installation Overview .....	6
3.1	Kit Layout & System Location(s) .....	6
3.2	Install Process Outline.....	7
3.3	Approximate Installation Time.....	7
4	List of Tools & Supplies .....	8
4.1	Standard Tool List (Required) .....	8
4.2	Special Tool List (Recommended).....	8
4.3	Shop Consumables List (Recommended).....	8
5	Parts List.....	9
5.1	Review Parts List .....	9
5.2	Pre-Packaged Electromechanical Kit Items.....	9
5.3	Pneumatic Components.....	9
5.4	Electrical Components .....	10
5.5	Mounting Brackets.....	11
5.6	Hardware .....	11
5.7	Special Parts.....	13
6	Bench Assembly .....	14
6.1	Install Air Fittings .....	14
6.1.1	Air Tank Fittings .....	14
6.1.2	1302 Quick Connect (On-Board Air).....	14
6.1.3	INF-1 & Air Horns .....	15
6.2	Tank Brackets.....	15
6.2.1	Rubber Trim .....	15
6.2.2	Tank Strap Installation .....	16
6.3	Air Horn Driver Hardware .....	18



6.3.1	Rear Horn Bracket Preparation.....	18
6.3.2	Front Horn Bracket Preparation.....	18
7	On-Vehicle Installation.....	19
7.1	Nut Plates & Tank/Compressor Bracket Installation .....	19
7.2	Rear Tank Bracket Installation .....	22
7.3	Compressor Installation .....	24
7.4	Tank Installation.....	25
7.5	Front Horn Bracket Installation.....	27
7.6	Rear Horn Bracket Installation.....	31
7.7	Air Horn Installation.....	34
8	Pneumatic Tubing Routing & Plumbing.....	35
9	Electrical Wiring.....	36
10	Final Steps & Testing.....	38
10.1	Reconnect Vehicle Battery(s).....	38
10.2	If removed, reinstall the fuse.....	38
10.3	Test Air Compressor.....	38
10.4	Test Train Horns.....	38
10.5	Test Quick Connect Coupler.....	38
11	General Operation .....	39
11.1	Compressor Operation.....	39
11.2	Horn Operation .....	39
12	Routine Maintenance .....	39
13	Warranty Information.....	40

END OF TABLE OF CONTENTS



## 1 Safety First

Read manual thoroughly before starting installation of this kit. Verify that you have all parts listed, and that you clearly understand the installation procedure. Contact Kleinn technical support with any questions.

Installation of this kit requires **moderate mechanical aptitude**; seek professional help if you're not competent using hand tools in tight uncomfortable spaces and around possibly rusted and sharp vehicle parts.

Before starting, obtain proper tools required to perform installation correctly, adequate lighting, eye protection, hearing protection, (for operating train horns) and hand protection to guard against sharp edges and metal burrs which may be present on kit parts and/or vehicle parts.

Throughout this manual the following words may be used; be aware of their meaning and application.

**CAUTION:** means damage could occur to vehicle or kit parts during or after installation.

**WARNING:** means injury could occur to you or others, including damage to vehicle or kit parts.

**DANGER:** means serious injury or death could occur to you or others during installation.

END OF SECTION



## 2 Application Chart

### 2.1 Bolt-On Vehicle List

RPTR-OBA/734 is a 100% direct bolt-on aftermarket product for the Ford Vehicles listed below. Every effort has been made to verify fitment on these vehicles in their factory condition.

MODEL YEAR	MODEL	DRIVE	ENGINE	BODY	TRIM
2017-2020	F-150 RAPTOR	4WD	3.5L EcoBoost	SuperCrew	ALL

NOTE: Vehicle may require drilling holes for electrical ground points, wiring, switches, and on-board air based on preference.

### 2.2 Excluded Vehicles

The following vehicles have been found to be **incompatible** with the designed kit:

MODEL YEAR	MODEL	DRIVE	ENGINE	BODY	TRIM
2017-2020	F-150 RAPTOR	4WD	3.5L EcoBoost	SuperCab	ALL

### 2.3 Aftermarket Product Compatibility

**NOTE:** Before installing this product on a vehicle with any aftermarket parts attached in regions shown in this manual, thoroughly review this manual to verify necessary mounting points and overall space exists. At the discretion of end-user/installer, included Brackets/components may require modifications to attach to vehicles with aftermarket parts. **THIS VOIDS THE KLEINN WARRANTY.**

This kit has **not** been designed to work with the following aftermarket products:

- This kit has NOT been designed or tested for use with aftermarket power truck steps which attach to the inside of the rocker panel.
- This kit has NOT been designed or tested for use with aftermarket truck steps, which attach to the frame.
- This kit has NOT been designed or tested for use with aftermarket exhaust systems.
- This kit has NOT been designed or tested for use with aftermarket suspension systems.

**NOTE:** Review this manual in full before unpacking items to verify correct space and mounting locations exist with your aftermarket product(s). *To install this kit alongside your other aftermarket product(s), modification to the included parts, your vehicle, or your aftermarket product(s) may be required.*

END OF SECTION

### 3 Installation Overview

#### 3.1 Kit Layout & System Location(s)

This kit consists of the following components, located on vehicle as follows:

Item No.	Component	Vehicle Location	Install Time (APPROXIMATE)
1	6450RC 150 PSI Waterproof Compressor	Outer passenger side frame rail, in between front/rear door	2+ Hours
2	3 Gallon Air Tank	Outer passenger side frame rail, under rear door	2+ Hours
3	Model 730 Demon Triple Train Horn	Outer driver side frame rail, under rear door	1-2 Hours
*4	Remote Quick-Connect Coupler	To be determined by installer	Up to 1 Hour

\*Not Illustrated

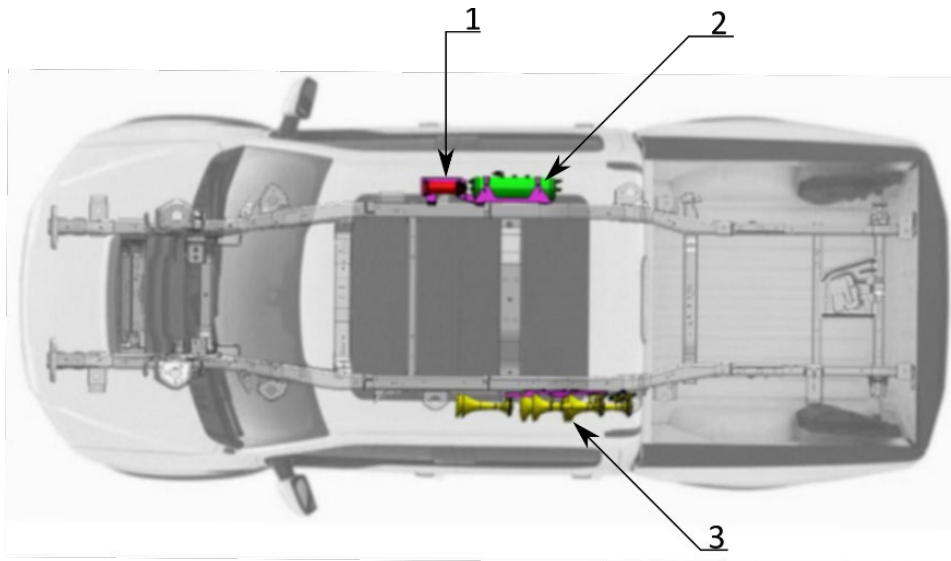

Figure 1- Component Location Overhead View

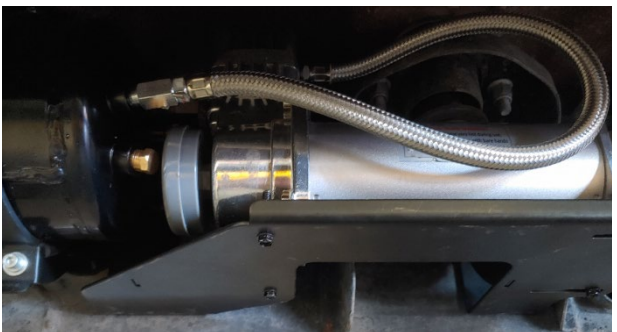

Figure 2- Compressor Installed



Figure 3- Tank Installed



Figure 4- Horns Installed

### 3.2 Install Process Outline

**For person(s) with prior experience installing this kit, a reminder of the install steps is provided below:**

1. Layout all components of kit
2. Assemble fittings to Air Tank, On-board Air Kit, Tire Inflation Kit & Air Horns
3. Pre-assemble & prepare brackets for installation
4. Install the nut plates
5. Install the compressor bracket
6. Install the forward tank bracket
7. Install the rear tank bracket
8. Install & connect the tank & compressor
9. Install the horn brackets (if applicable)
10. Install and plumb the air horns
11. Install and plumb the On-board air relocation kit
12. Route & connect the air tubing
13. Route and connect the wiring
14. Test the system

### 3.3 Approximate Installation Time

**This kit is a multi-faceted product consisting of mechanical, electrical, and pneumatic components.**

For a typical home mechanic, auto enthusiast, or technician installing this kit for first time; a professional installation job with setup and testing of final product, is estimated to take:

- **6-12 Hours**

END OF SECTION



## 4 List of Tools & Supplies

### 4.1 Standard Tool List (Required)

1. Basic mechanic's 3/8" drive socket sets with extensions
  - Inch size sockets
  - Metric size sockets
2. Basic mechanic's combination wrenches (box/open-end)
  - Inch size wrenches
  - Metric size wrenches
3. Basic mechanic's screwdriver set (Philips, Flat Head)
4. Diagonal cutter/wire cutter pliers
5. Wire strippers
6. Wire terminal crimpers
7. Slip-joint pliers
8. Vise grips or locking pliers
9. Small pry bar or large flat blade screwdriver
10. Utility knife
11. Magnetic retrieval tool

### 4.2 Special Tool List (Recommended)

1. 10-100 ft-lbs. torque wrench
2. 20-150 in-lbs. torque wrench
3. Multi-meter or 12V DC test light or equivalent
4. Trim panel tool, for removing wiring and body clips, when needed

### 4.3 Shop Consumables List (Recommended)

1. Quality electrical tape
2. Di-electric grease for electrical connections
3. Heat shrink tubing for electrical connections
4. Medium-strength thread-locker (i.e., Blue Loctite® PN 242) or equivalent
5. Low-strength thread-locker (i.e., Purple Loctite® PN 222) or equivalent
6. Black/Clear silicone for drilling holes in body
7. Sandpaper or wire brushes for installing ground wires
8. Extra plastic zip ties > 6" long
9. Extra NPT sealant (i.e., Kleinn Air Horn Juice, Teflon tape, etc.)
10. Touch-up paint for frame/chassis/body (i.e., primer or black epoxy)
11. Typical cleaning supplies

END OF SECTION



## 5 Parts List





This section should be printed to expedite the installation process.

### 5.1 Review Parts List



Unpackage and organize kit and verify all parts are included, as listed below. Contact Kleinn support with any questions.

### 5.2 Pre-Packaged Electromechanical Kit Items

**NOTE:** Items in this section come in their own packages and may include additional items inside package.





Item No	Qty	Part Number	Description	Picture
1.	1	6450RC	150 PSI Air Compressor	
2.	1	730	Model 730 Triple Train Horns	
3.	1	1302L	Remote Quick Connect Coupler Kit	
4.	1	INF-1	Tire Inflation Kit	

### 5.3 Pneumatic Components

Item No	Qty	Part Number	Description	Picture
5.	1	6353RT	2.8 Gallon Air Tank, 9 NPT Ports	
6.	1	52835	Drain Valve, 1/4" NPT	
7.	1	52175	175 PSI Safety Valve, 1/4" NPT	

8.	3	50040	Hex Plug, ¼" NPT	
9.	1	51414L	90° Elbow Fitting, ¼" NPT to ¼" Compression	
10.	1	51214L	90° Elbow Fitting, ¼" NPT to ½" Compression	
11.	1	2151	Pressure Switch, ¼" NPT	
12.	10 ft	25014	Black Air Tubing, ¼"	
13.	1	JUICE	Kleinn Air Horn Juice – Thread Sealant	



#### 5.4 Electrical Components











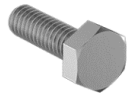



Item No	Qty	Part Number	Description	Picture
14.	1	320	Terminator Horn Button	
15.	1	WIRE KIT	Complete wire kit w/ electrical connectors & zip ties	
16.	20 ft	WIRE LOOM	¼" Split Wire Loom, Black	
17.	10 ft	WIRE LOOM	1/8" Split Wire Loom, Black	

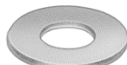

### 5.5 Mounting Brackets

Item No	Qty	Part Number	Description	Picture
18.	1	RAPTOR-110	Compressor Bracket	
19.	2	RAPTOR-202	Tank Strap	
20.	2	RAPTOR-203	Nut Plate	
21.	1	RAPTOR-210	Rear Tank Bracket	
22.	1	RAPTOR-211	Front Tank Bracket	
23.	1	RAPTOR-310	Rear Horn Mount	
24.	1	RAPTOR-311	Front Horn Mount	

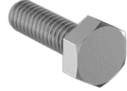
### 5.6 Hardware

Item No	Qty	Description	Picture
H1.	4	Socket Head Cap Screw – ¼”-20, 1” Long	
H2.	2	Phillips Pan Head Screw – ¼”-20, .75” Long	

H3.	4	Hex Bolt – 5/16”-18, 1” Long	
H4.	4	Carriage Bolt (knurled) – 5/16”-18, .75” Long	
H5.	6	Carriage Bolt (square neck) – 5/16”-18, 1.25” Long	
H6.	1	Carriage Bolt (knurled) – 5/16”-18, 1” Long	
H7.	4	Lock Washer – ¼”	
H8.	15	Lock Washer – 5/16”	
H9.	4	Flat Washer – ¼”, .63” OD	
H10.	15	Flat Washer – 5/16”, .69” OD	
H11.	4	Flat Washer – 5/16”, .88” OD	
H12.	1	Fender Washer – 5/16”, 1.25” OD	
H13.	11	Hex Nut – 5/16”-18	
H14.	1	Clip-on Barrel Nut – M8 x 1.25	
H15.	*	Hex Bolt – M8 x 1.25	
H16.	*	Lock Washer – M8	

H17.	*	Flat Washer – M8, 16mm OD	
H18.	**	Compressor Mounting Hardware - Assorted	

\*Included inside Horn Box

\*\*Included inside Compressor Box

### 5.7 Special Parts

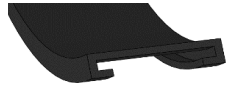
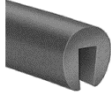
Item No	Qty	Description	Picture
25.	2	Rubber Trim (wide “C”) – 9” Strip	
26.	2	Rubber Trim (narrow “U”) – 9” Strip	

END OF SECTION

## 6 Bench Assembly

Complete the following steps off vehicle to facilitate final installation.

### 6.1 Install Air Fittings

Gather the air fittings for installation on the following components (as applicable):

- Air Tank
- 1302 Quick Connect Bracket
- INF-1 Inflator Kit
- Air Horns

---

Apply two drops of Item 13 (JUICE) to each male pipe thread before installation.

Hand-tighten each fitting, then further tighten  $\frac{1}{4}$  to  $\frac{1}{2}$  turn as necessary to match the fitting orientation shown in the below figures.

---

#### 6.1.1 Air Tank Fittings

Attach air fittings to the tank per the below figure.

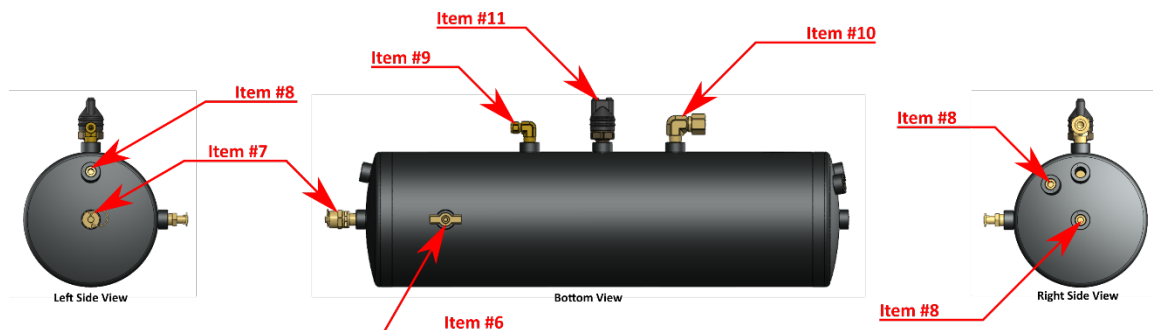

Figure 5- Tank Fitting Installation

#### 6.1.2 1302 Quick Connect (On-Board Air)

1. Attach air fittings per the below figure.
2. Reference the 1302 Remote Quick Connect Instructions at [Kleinn.com](http://Kleinn.com) for more information.

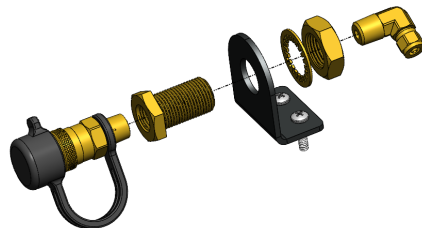

Figure 6- 1302 Quick Connect Assembly

### 6.1.3 INF-1 & Air Horns

1. Install the fittings (located in the INF-1 Bag) to the INF-1 kit.

For the following step, separate the medium air horn trumpet from the base as shown below.

2. Install the air valve onto the medium horn driver fitting with the direction of flow (arrow indicator) pointed towards the air horn driver. The black housing should be oriented as shown below.

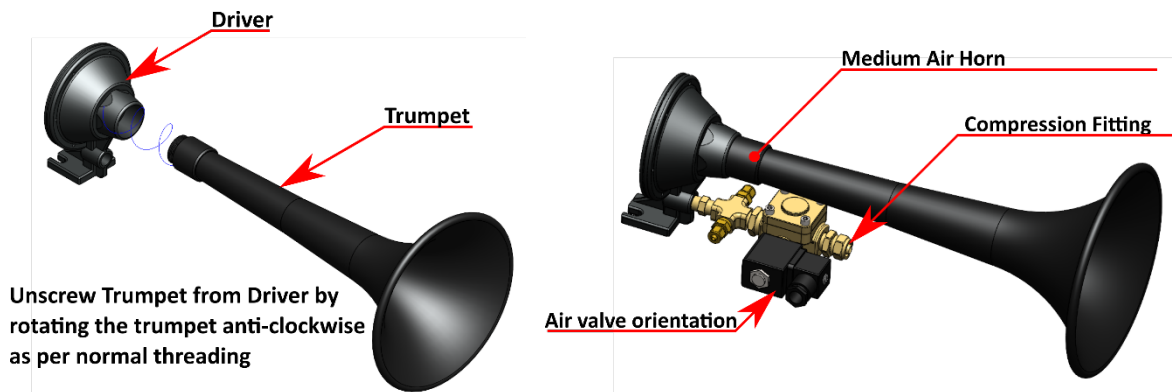

Figure 7- Horn Solenoid Orientation

3. Install the supplied compression fitting onto the inlet port of the solenoid.

## 6.2 Tank Brackets

The following brackets & hardware are used in this step:

- Item 19 = RAPTOR-202 – Qty: 2
- Item 21 = RAPTOR-210
- Item 22 = RAPTOR-211
- Item H1, H7, H9 – Qty: 4 each
- Item 25 & 26 – Qty: 2 each

---

*Note: Tank straps may come pre-bent, if so, skip steps 6.2.2 Step #3 – 6.2.2 Step #7*

---

### 6.2.1 Rubber Trim

Trim item 25 & 26 to fit (if needed) and install onto RAPTOR-202 & RAPTOR-210, -211 as shown in the following figure.

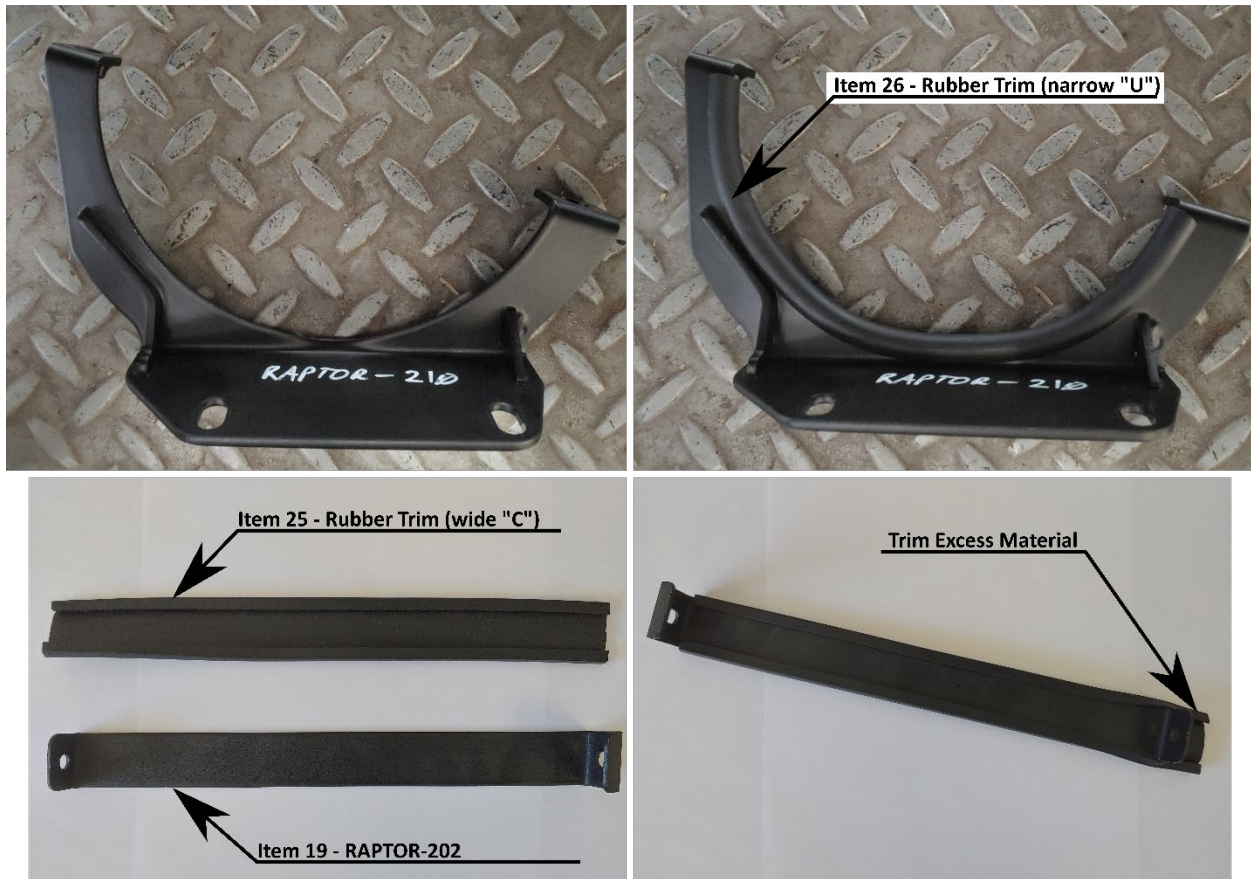

Figure 8- Rubber Trim Installation

### 6.2.2 Tank Strap Installation

1. Take hardware H1, H7, & H9 and insert into the hole (**NOT SLOT**) of Item 19 (tank strap) in the stacking order shown below.

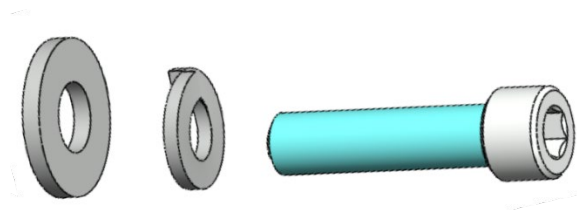

Figure 9- Tank Strap Hardware Stacking Order



2. Install onto the upper threads of the brackets (Item 21 & 22) as shown below.

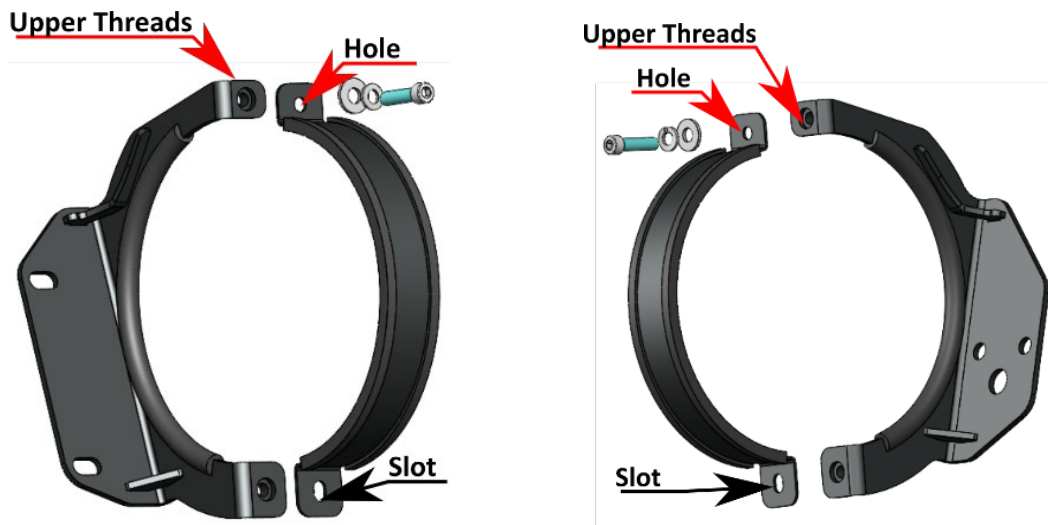

Figure 10- RAPTOR-210 (Left) & -211 (Right) – Straps are shown pre-bent

3. If straps are not pre-bent, place Item 5 (Air Tank) onto the brackets RAPTOR-210 & -211 (Item 21 & 22).
4. Place hardware H1, H7, & H9 in the stacking order above, onto the slotted hole in the Tank strap & form the strap to match the contour of the tank.
5. As you form the strap, align the fastener to the bottom threaded hole on the bracket and fasten the strap & tank completely to the bracket.
6. Repeat for the second strap.
7. Once the straps are formed, Remove the lower fasteners and remove the tank. Set aside for future use. Keep the upper fasteners in place, securing the straps to the brackets.

### 6.3 Air Horn Driver Hardware

The following brackets & hardware are used in this step:

- Item 23 = RAPTOR-310
- Item 24 = RAPTOR-311
- Item H5, H8, H10, H13 – Qty: 6 each

#### 6.3.1 Rear Horn Bracket Preparation

Loosely install hardware H5, H8, H10, H13 onto bracket RAPTOR-310 as shown in the below figure. Verify hardware stacking and install locations match the figure.

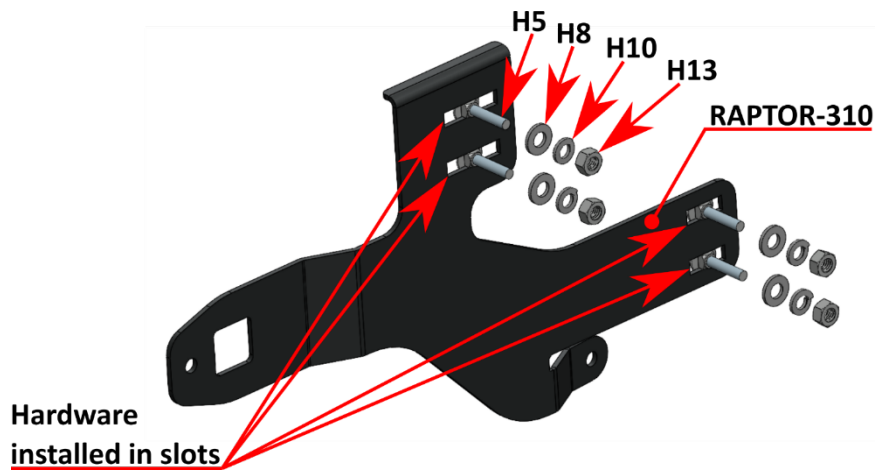

Figure 11- Rear Bracket Horn Driver Hardware Installation

#### 6.3.2 Front Horn Bracket Preparation

Loosely install hardware H5, H8, H10, H13 onto bracket RAPTOR-311 as shown in the below figure. Verify hardware stacking and install locations match the figure.

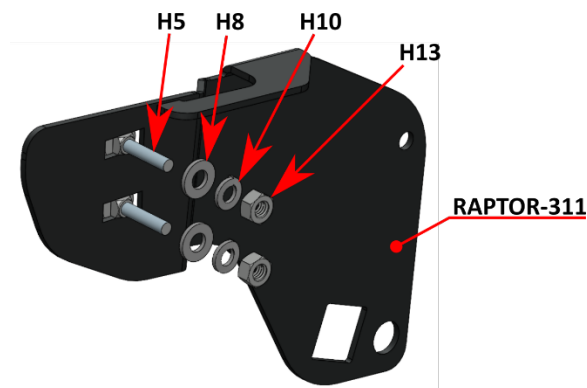

Figure 12- Front Bracket Horn Driver Hardware Installation

END OF SECTION

## 7 On-Vehicle Installation

### 7.1 Nut Plates & Tank/Compressor Bracket Installation

The following brackets & hardware are used in this step:

- Item 18 = RAPTOR-110
  - Item 20 = RAPTOR-203 – Qty: 2
  - Item 22 = RAPTOR-211
  - Item H2 – Qty: 2
  - Item H3, H8, H10 – Qty: 4 each
1. Thread H2 into RAPTOR-203 approximately halfway (**REF. Below**).
  2. Thread Qty: 1 H3 approximately halfway, into left or right hole of RAPTOR-203 temporarily as shown below.

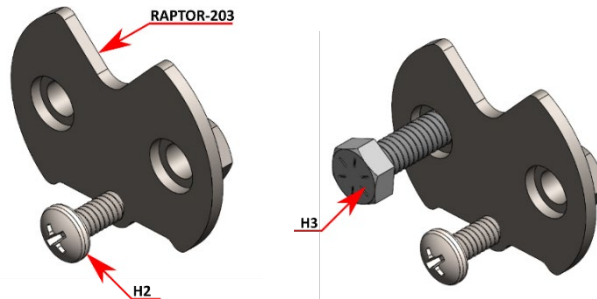

Figure 13- Nut Plate Preparation – Step 1 (Left), Step 2 (Right)

3. Locate 2 oval holes on passenger side frame rail in-between the front & rear door as shown.



Figure 14- Raptor-203 Install Location

- Use H3 as a handle to insert RAPTOR-203 into the oval frame rail holes & secure by tightening H2 as shown below.

*Note: Ensure RAPTOR-203 holes are parallel to the floor and are not obstructed by the frame.*

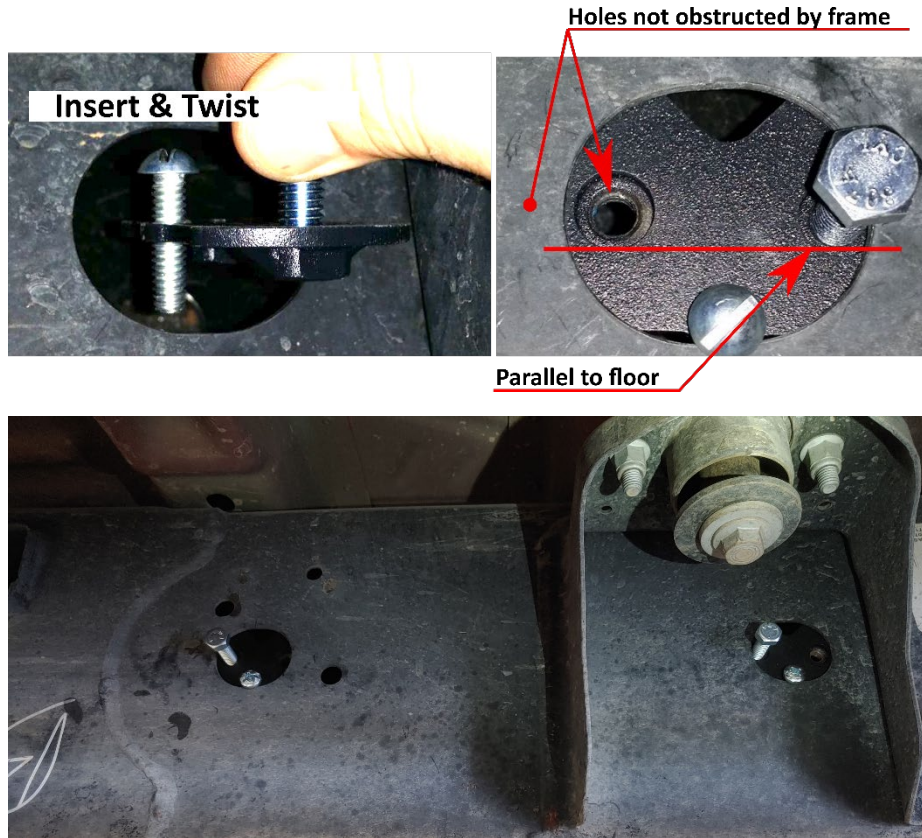

Figure 15- RAPTOR-203 Installation

- Remove the H3 from both RAPTOR-203's to be reused.
- Take Qty: 2 of each H3, H8, H10 in the below stacking order and install RAPTOR-110 onto the front-most RAPTOR-203 as shown below.

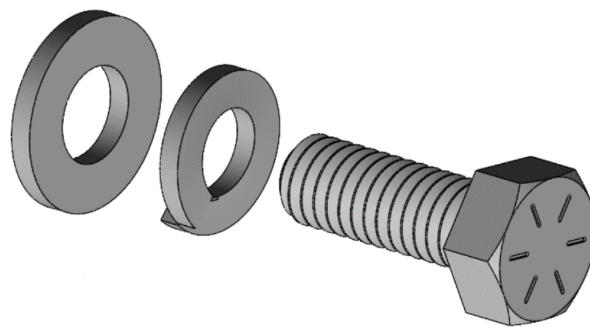
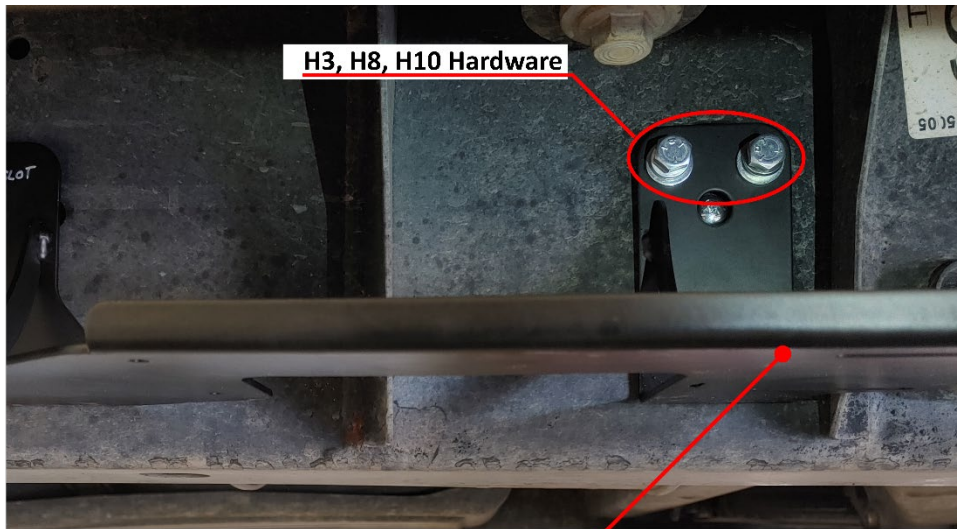

Figure 16- RAPTOR-110 Hardware Stacking Order



**RAPTOR-110 Installed on foremost RAPTOR-203 bracket**

*Figure 17- RAPTOR-110 Install*

7. On rearmost RAPTOR-203, use the remaining H3, H8, H10 hardware in the same stacking order & install RAPTOR-211 in-between the frame & RAPTOR-110 rear hole as shown below.



*Figure 18- RAPTOR-110 & -211 Install*

8. Torque fasteners to 75-88 in-lbs.

## 7.2 Rear Tank Bracket Installation

The following brackets & hardware are used in this step:

- Item 21 = RAPTOR-210
- Item H4, H8, H10, H11, H13 – Qty: 2 each

Use the below stacking order for installation of the RAPTOR-210 bracket.

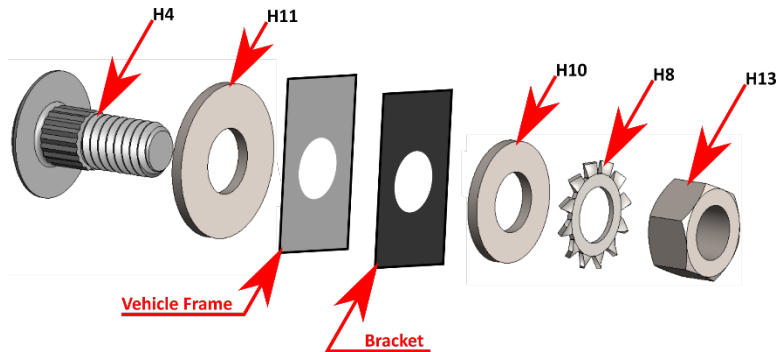

Figure 19- RAPTOR-210 Hardware Stacking Order

1. Locate the square & circular holes on the passenger side frame rail below the rear door as shown.

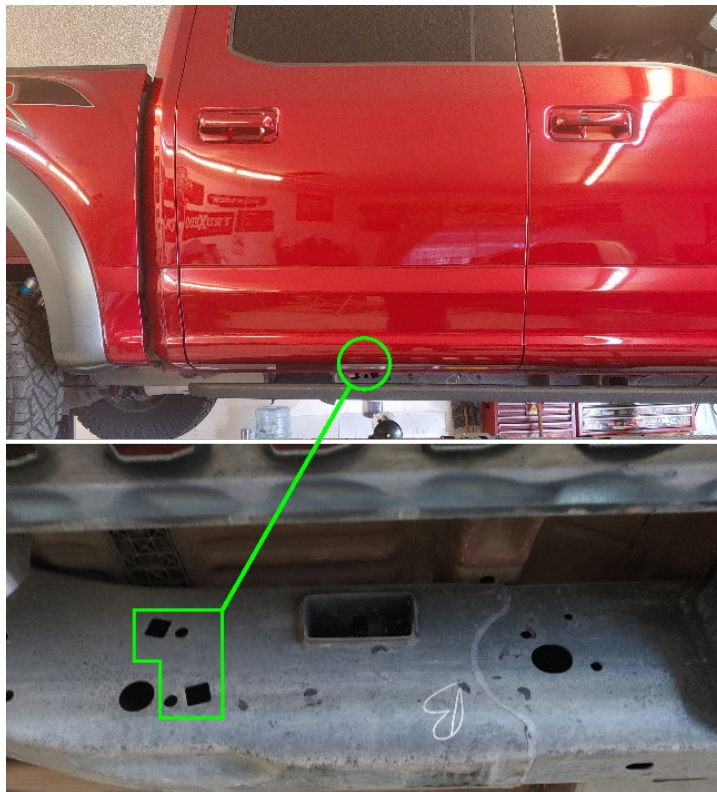

Figure 20- RAPTOR-210 Install Location

H4 & H11 secure the RAPTOR-210 bracket from inside the frame rail.

2. Insert H4 & H11 (stacked) into the square holes and orient the threads to face outside of the frame rail through the circular hole. Reference the following figure.

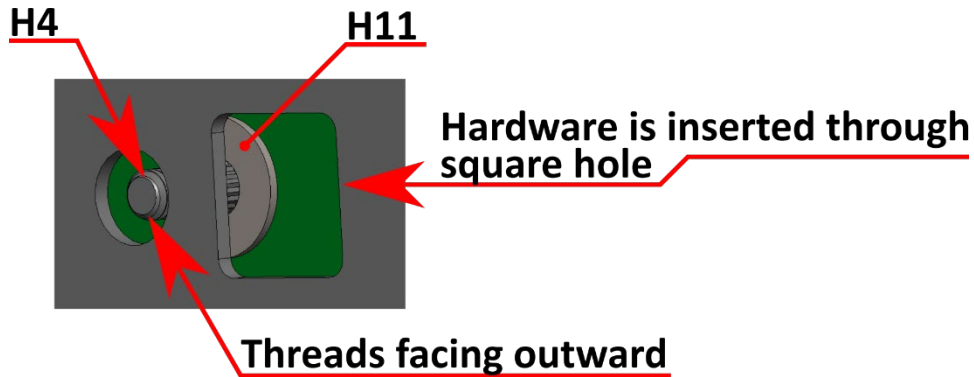

Figure 21- Example of Hardware Setup

3. Place RAPTOR-210 onto the H4 bolt and install the remaining hardware H10, H8, H13 onto the bolt and loosely fasten to allow the installation of the hardware in the second location.
4. Repeat this process for the second hole location

---

*Note: Ensure the folded tabs of RAPTOR-210 are facing the front of the vehicle as shown below.*

---

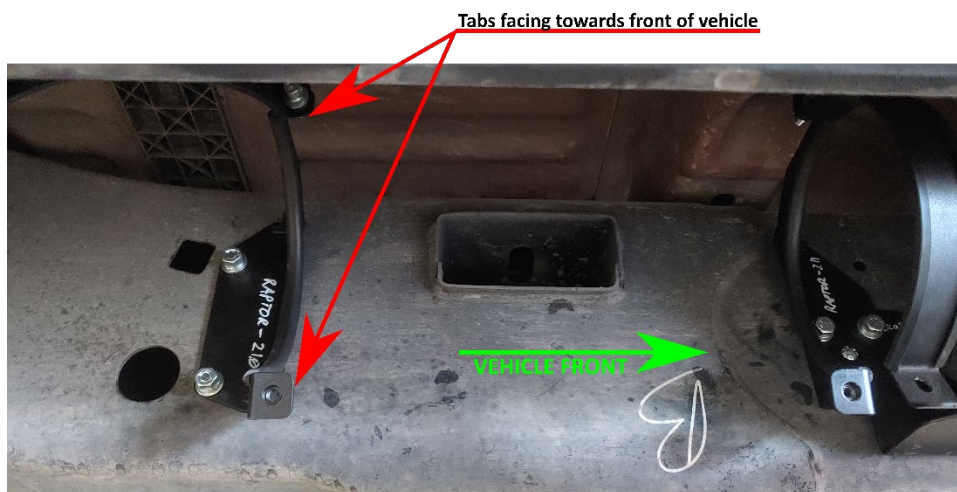

Figure 22- RAPTOR-210 Installation

5. Torque hardware to 75-88 in-lbs.

### 7.3 Compressor Installation

The following hardware is used in this step:

- Item 1 = Compressor
- All included hardware and components inside the compressor box

Use the below stacking order for installation of the compressor.

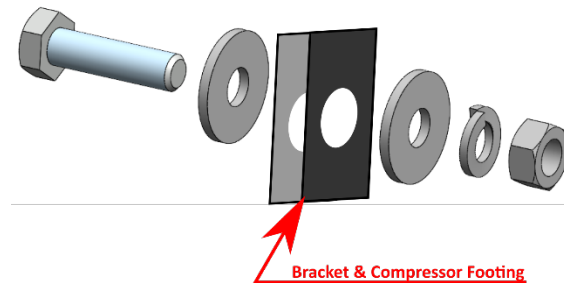

Figure 23- Compressor Hardware Stacking Order

1. Use the instructions included in the compressor box to install the air filter media into the air filter housing.
2. Install the air filter onto the inlet of the compressor. Alternately you may install the air filter remotely using the instructions included in the compressor box.
3. Place the compressor onto the RAPTOR-110 bracket, with the head of the compressor toward the rear of the vehicle as shown.

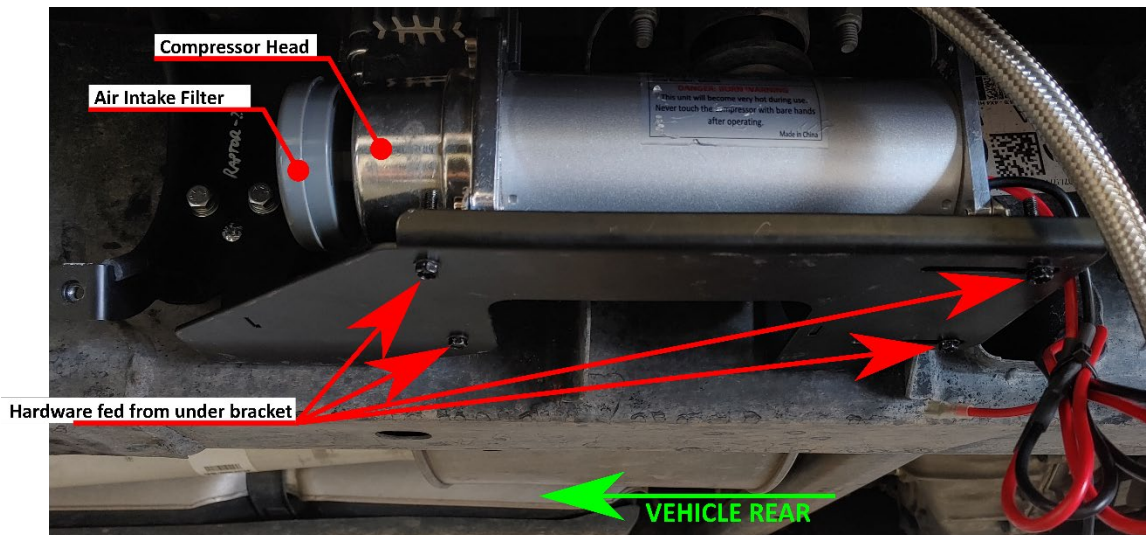

Figure 24- Compressor Installation

4. Install the compressor onto RAPTOR-110 using the hardware included in the compressor box. Insert the hardware from the underside of the bracket as shown in the above figure.
5. Torque the hardware to 20 in-lbs.



## 7.4 Tank Installation

The following components & hardware are used in the step:

- Item 5 = Air Tank
- Item H1, H7, H9 – Qty: 2 each

Use the following stacking order for installation of the tank.

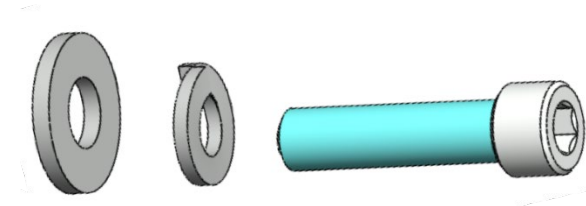

Figure 25- Lower Tank Strap Hardware Stacking Order

1. Using the below figure to ensure tank orientation is correct; guide the air tank into position onto the tank brackets RAPTOR-210 & -211 beginning from the rear bracket & maneuvering it towards the compressor.



Figure 26- Air Tank Install Orientation

2. Align the drain valve towards the ground to facilitate draining the tank (periodic maintenance).
3. Use the hardware H1, H7, H9 to fasten the tank via the tank straps (RAPTOR-202's) lower slotted hole.
4. Attach the Compressor leader hose to the unused bung on the tank (triple bungs). Hand tighten the fitting then snug ¼ turn more. Reference the following figures.

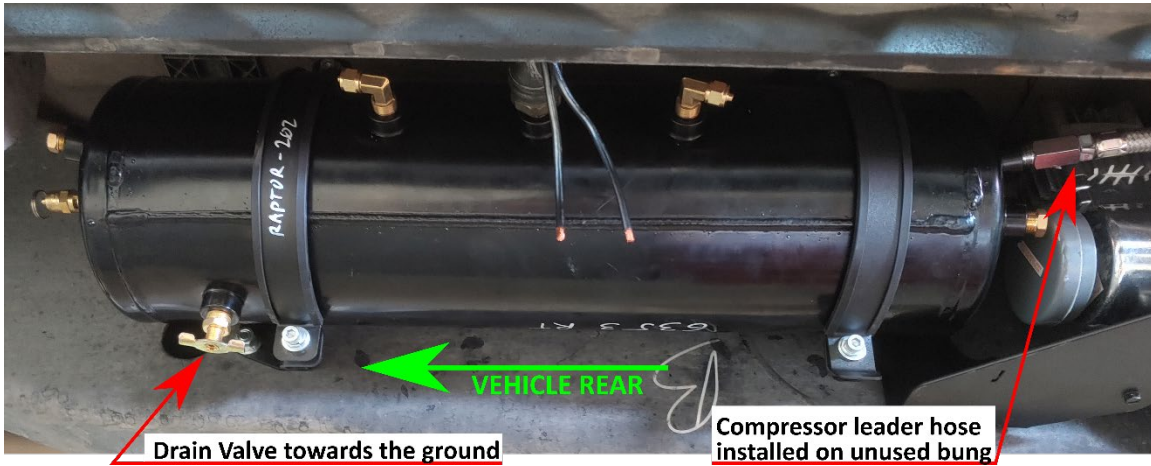

Figure 27- Air Tank Installed

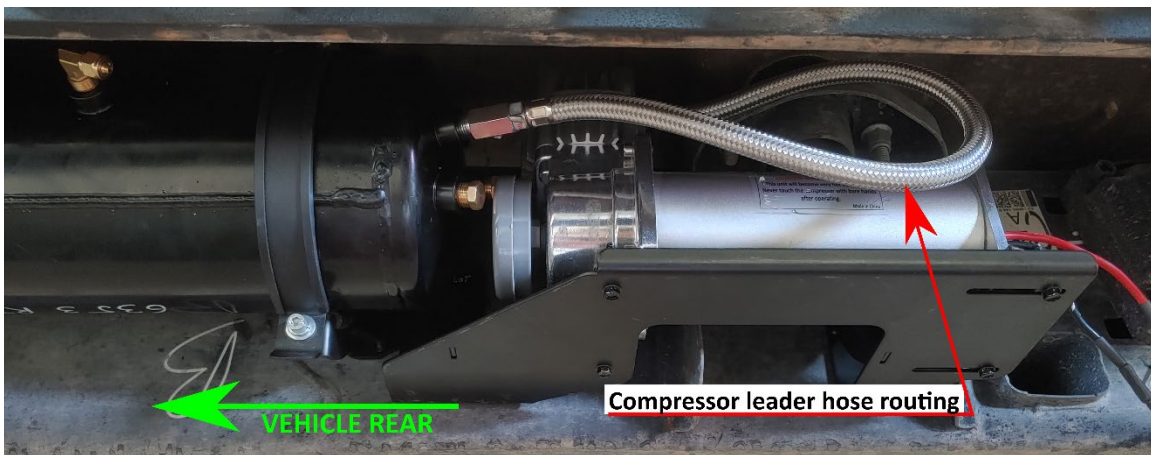

Figure 28- Compressor Leader Hose Routed to Air Tank

5. Torque tank straps (RAPTOR-202's) hardware to 37 in-lbs.

## 7.5 Front Horn Bracket Installation

The following brackets & hardware are used in this step:

- Item 24 = RAPTOR-311
- Item H4, H8, H10, H11, H13 – Qty: 1 each
- (Optional) Item H14, H15, H16, H17

Use the below stacking order for installation of the RAPTOR-311 bracket.

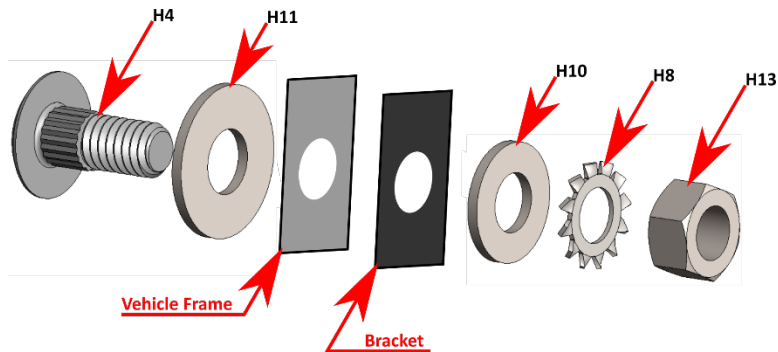

Figure 29\_ RAPTOR-311 Hardware Stacking Order

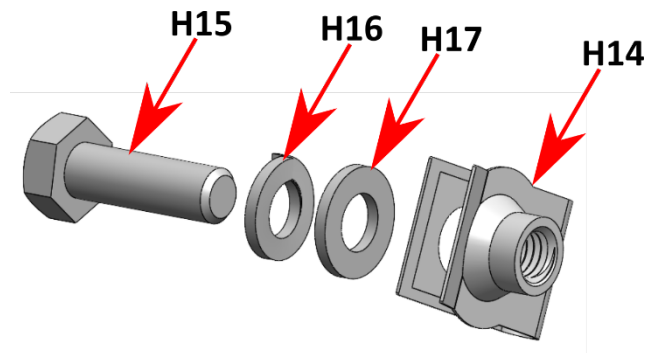

Figure 30- RAPTOR-311 Optional Hardware Stacking Order

---

*Some vehicles will be equipped with a parking cable bracket in the install location. If so, the optional hardware listed above **WILL NOT** be used.*

---

1. Locate the square & circular holes on the driver side frame rail, under the rear door. This cluster of holes will be next to a rectangular crossmember & may have the parking cable & its respective bracket attached (if applicable). Reference the following figure.

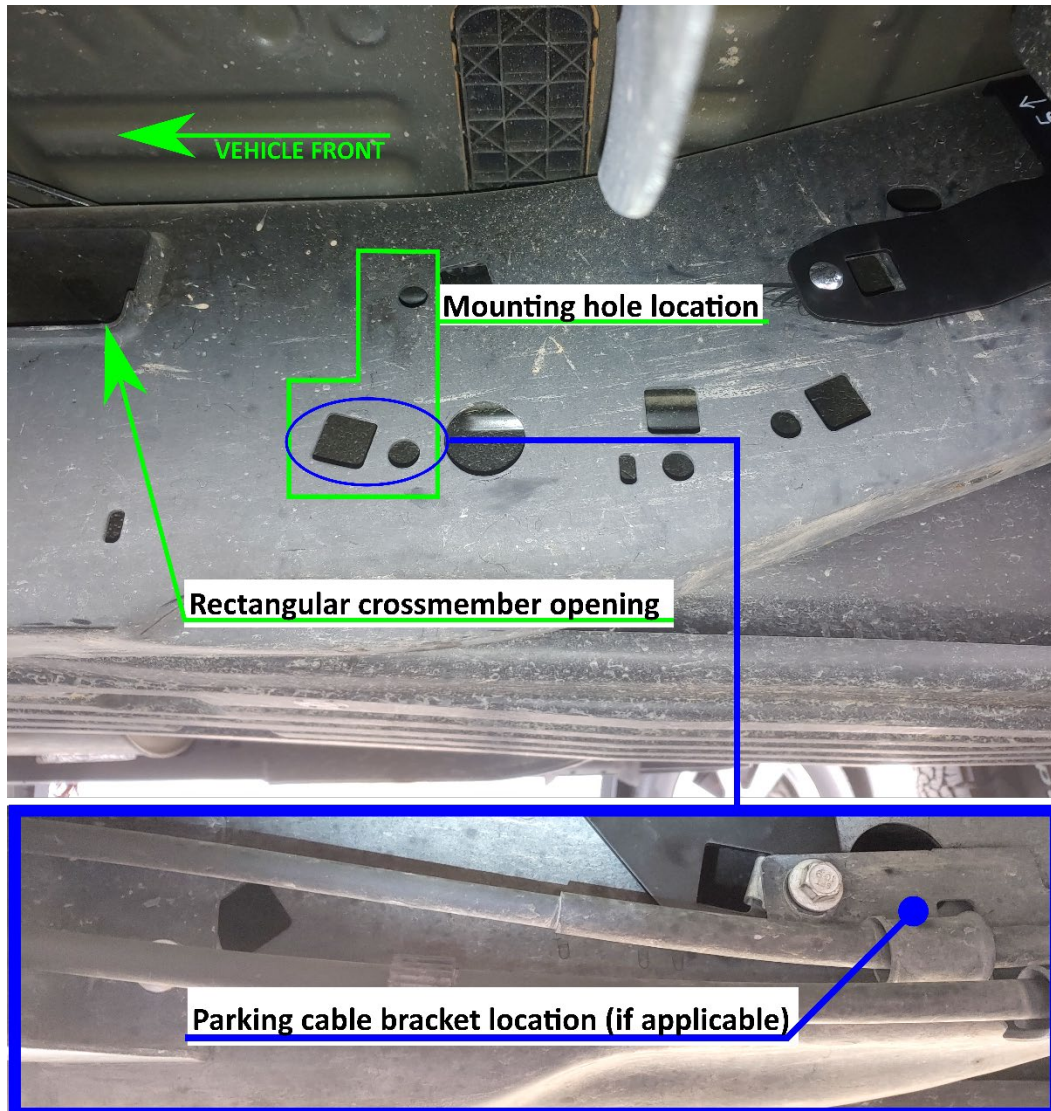

Figure 31- RAPTOR-311 Mounting Holes Location

---

Vehicles that **DO NOT** have the parking brake cable assembly, follow the same steps except where noted [Alternate] & additionally use the “optional” hardware listed at the beginning of this section.

---

Vehicles that **DO NOT** have the parking brake cable assembly, skip Steps 2 & 3.

2. Remove the bolt holding the Parking Brake bracket & set aside for re-use.
3. Move aside the parking brake bracket to facilitate horn bracket installation. The following figure shows the bracket orientation for installation.



Figure 32- RAPTOR-311 Install Orientation

4. Slide RAPTOR-311 under the clip-on nut (via the square hole) to set it into place along the frame rail. The -311 bracket should lie in-between the vehicle frame & the clip-on nut as shown in the below figure.
  - a. *Alternate: Slide H14 onto the frame rail lower bracket mounting point (ref. the above Figure 31 **BLUE** section) to facilitate RAPTOR-311 installation.*



Figure 33- RAPTOR-311 Installed via Lower Mounting Point

5. Re-install the OEM bolt & parking brake cable bracket loosely.
  - a. *Alternate: Place RAPTOR-311 lower mounting point over the clip-on nut and secure in place using H15, H16, H17 in the stacking order shown in the beginning of this section.*
6. For the bracket -311 upper mounting point, insert H4 & H11 (stacked) into the square hole and orient the threads to face outside of the frame rail through the circular hole. Reference the following figure.

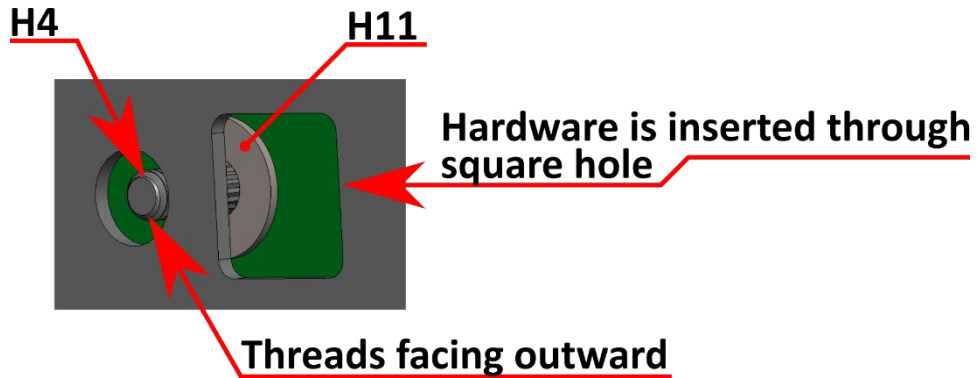

Figure 34- RAPTOR-311 Upper Mounting Point Hardware Setup

7. Place -311 upper mounting hole onto the hardware & install H8, H10, H13 in the stacking order (noted in the beginning of this section) onto the fastener as shown in the below figure.



Figure 35- RAPTOR-311 Installed

8. Torque parking brake bracket bolt to OEM specifications
  - a. *Alternate: Torque lower fastener to 75-88 in-lbs.*
9. Torque upper fastener to 75-88 in-lbs.

## 7.6 Rear Horn Bracket Installation

The following brackets & hardware are used in this step:

- Item 23 = RAPTOR-310
- Item H4, H6, H12 – Qty: 1 each
- H8, H10, H11, H13 – Qty: 2 each

Use the below stacking order for installation of the RAPTOR-310 bracket.

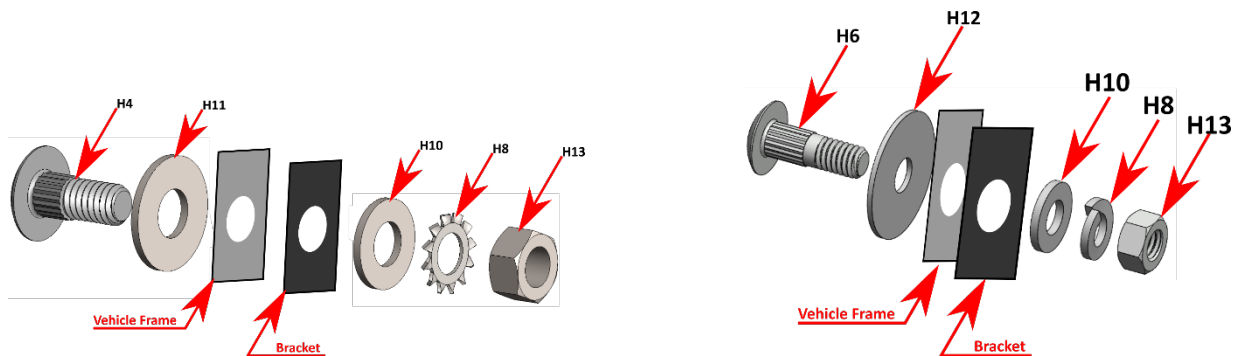

Figure 36- RAPTOR-310 Hardware Stacking Order - Frontmost Hole (Left), Rearmost Hole (Right)

1. Locate the RAPTOR-310 mounting holes on the driver side frame rail below the rear door, slightly forward of the front most leaf spring bolt as shown below.

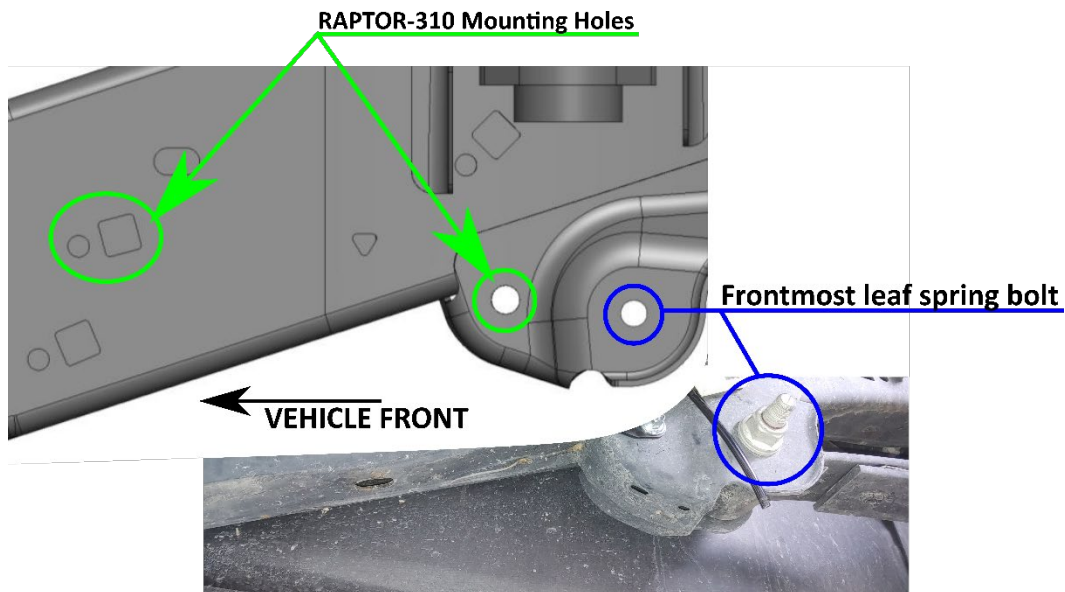

Figure 37-RAPTOR-310 Mounting Holes

2. Insert H6 & H12 (stacked per above order) from inside the frame, outwards, into the rearmost hole (closest to front leaf spring bolt).

3. Place RAPTOR-310 onto the frame & through the H6 hardware using the lower/rear mounting hole
4. Complete the hardware install per the above stacking order. This step is shown in the below figure.



*Figure 38- RAPTOR-310 Lower Mounting Point Installation*



5. Insert H4 & H11 (stacked) into the square hole and orient the threads to face outwards of the frame rail through the circular hole as done in the previous step.
6. Place RAPTOR-310 foremost mounting hole over the hardware and install H8, H10, H13 in the stacking order noted in the beginning of this section. Reference the following figure.



*Figure 39- RAPTOR-310 Fully Installed*

7. Torque mounting hardware to 75-88 in-lbs.

## 7.7 Air Horn Installation

---

*Installation of the air horns require the separation of the trumpets from the bases (drivers).*

---

1. Separate all the air horn trumpets from the drivers (bases) by unscrewing the trumpet from the driver as shown below.

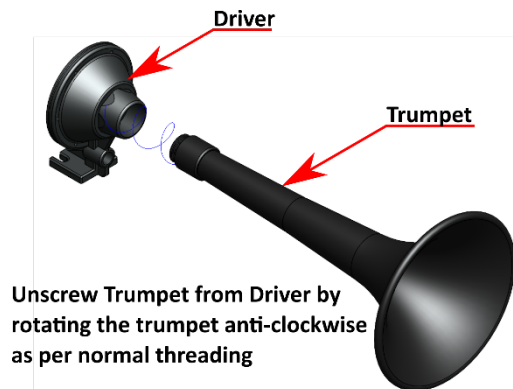

Figure 40- Air Horn Disassembly

2. Install the Drivers onto RAPTOR-310 & -311 brackets as shown below. The drivers are installed by being slid in-between the horn mounting hardware (previously installed) & the brackets.

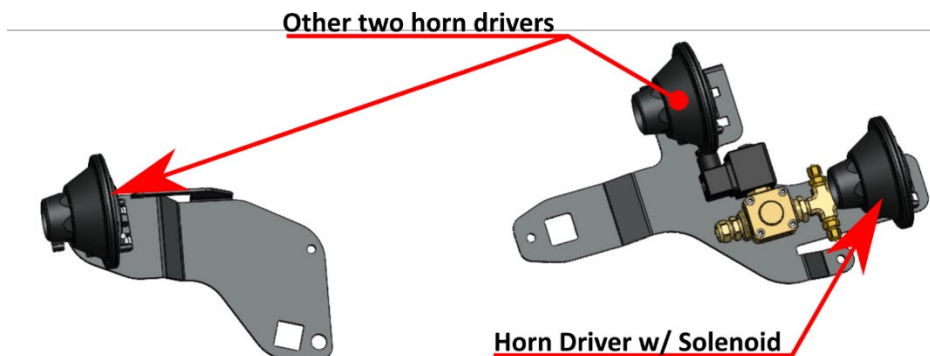

Figure 41- Horn Driver Installation

3. Route air tubing from the rearmost driver (with solenoid) to the other two horn drivers.
4. Leave hardware snug until all pneumatic routing is complete & trumpets are ready to be installed.

END OF SECTION

## 8 Pneumatic Tubing Routing & Plumbing.

With all components located, you are now able to route the air tubing as desired & install onto the compression / push-to-connect fittings as applicable.

Route the air tubing as desired to the different parts of the system. Use the below figure for proper hookup & the following tips for routing & installation.

- Tape off the exposed end of the air tubing so debris does not enter the line while you are routing the tubing through the vehicle.
- Use a heat gun to soften the ends of the air tubing to easily slide the tubing over the lip of compression fittings.
- Avoid routing the tubing through areas that move or are exposed to high heat.

*Note: The compressor should already be plumbed into the tank at this point. If not, do so now.*

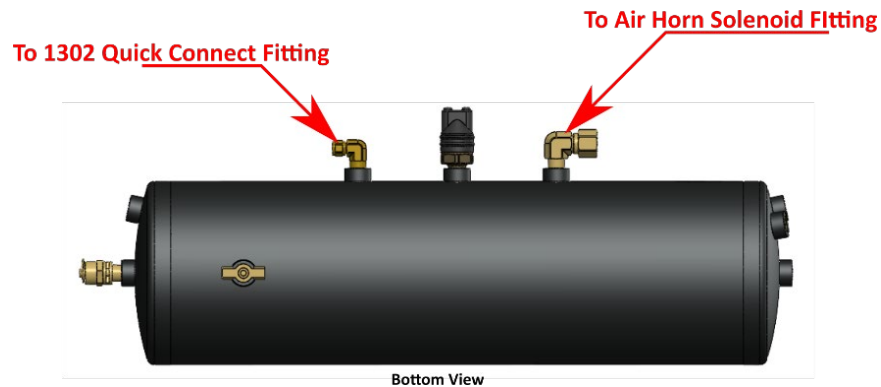

Figure 42- Air Tubing Plumbing

---

*Once air tubing is installed onto primary air horn driver, reinstall horn trumpets as shown in the below figure & final tighten the hardware that retains the air horns.*

---

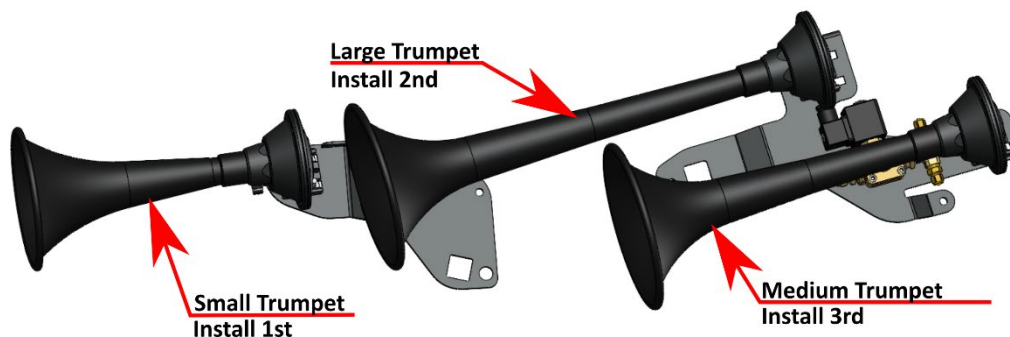

Figure 43- Air Horn Trumpet Installation Order

## 9 Electrical Wiring

**CAUTION:** Follow all recommended safety precautions for working on vehicle's electrical system; consult vehicle owner's manual for further instruction

Route & connect the wiring & electrical components as desired. Use the below figure & the following tips for routing & installation.

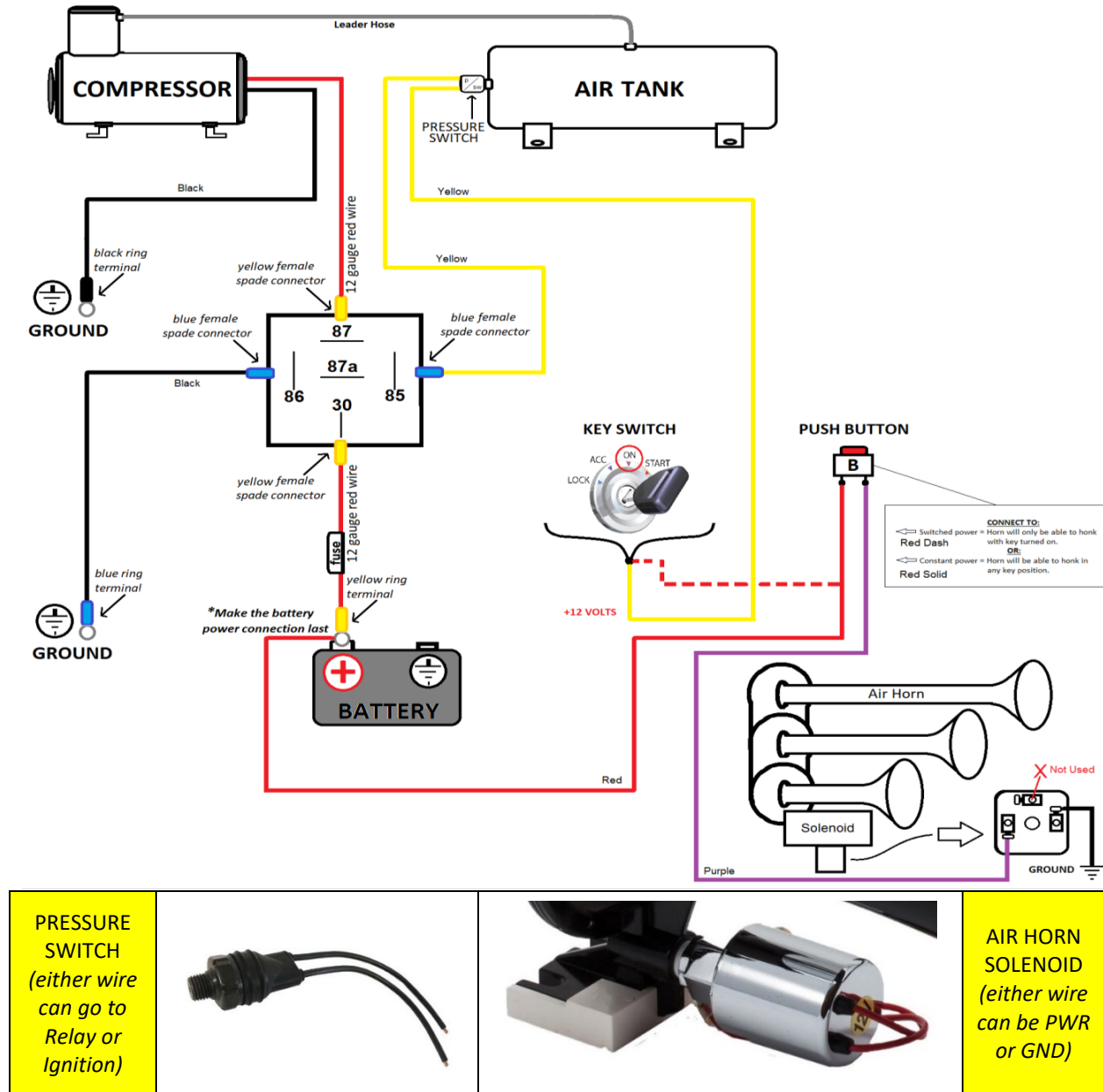

Figure 44- Suggested Wiring for Air Horn System

- It is recommended to disconnect the vehicle battery when performing wiring.
- Insert all wiring into the included wire loom & route loom away from sharp edges & high heat areas. Fasten securely using zip-ties or similar.
- Do not cut wires to length until you are 100% confident of the required length for final connections.
- The fuse holder comes looped & should be cut once location of fuse is decided.
- Remove fuse (if installed) until all electrical connections are complete & system is ready to be tested.
- The included push button can be installed in any location that has 1" of clearance behind the install surface. A  $\frac{3}{4}$ " hole should be drilled for the pushbutton.

**OEM upfitter switches may be used**



**Horn pushbutton installed in panel**

*Figure 45- Horn Pushbutton Install Example*

- If using OEM upfitter switches, consult the owner's manual for OEM switch wiring information.
- The relay comes with self-tapping screws to be used for securing the module in your preferred location.
- Either air horn solenoid wire can serve as the pos (+) signal wire or the ground (-) wire.
- Either pressure switch wire can be connected to the relay or the ignition line.

END OF SECTION



## 10 Final Steps & Testing

### 10.1 Reconnect Vehicle Battery(s)

**CAUTION:** Before connecting the vehicle battery(s), verify all wiring is properly connected and no shorts exists. Use of Multi-meter, or test light is recommended to check continuity of all connections.

### 10.2 If removed, reinstall the fuse.

### 10.3 Test Air Compressor

1. Turn the vehicle on and allow the compressor to fill the air tank. Initial fill may take up to 4 minutes. The air compressor should shut off automatically once full pressure is achieved.
2. If the compressor runs excessively, (i.e., 5 minutes or more) disconnect electrical power to the air compressor and listen for air leaks.
3. Inspect ALL air connections (i.e., air tank fittings, quick connect fittings, air horn fittings, etc.) for leaks by using a soap and water solution sprayed directly onto the fittings. The system must be pressurized, or the air compressor must be running.
4. If an air leak is found:
5. Safely release air pressure from system (i.e., slowly open drain valve).
6. Disassemble leaky connection, re-seal and reinstall fittings as needed.

### 10.4 Test Train Horns

1. Allow the air compressor to run and shut-off automatically (i.e., air tank is full)
2. Ensure all nearby persons have adequate hearing protection and provide courtesy warning to neighbors or others in vicinity.

**WARNING:** NEVER operate train horns with ears close to trumpets or in an enclosed space without [substantial hearing protection](#) (i.e., > Ear Plugs and Earmuffs) for all persons closer than 100 feet from vehicle. Never operate train horns outdoors when persons are near vehicle without adequate hearing protection.

3. Briefly activate the horns by pressing the horn button for one (1) second. Repeat three (3) times with a short rest period between (i.e., 1-3 seconds).
4. Horns should sound as expected and be loud. [click to listen to example 230 Kit](#)
5. Horn sound/loudness will taper quickly as the air tank pressure decreases.
6. Allow the air compressor to refill the tank, if needed, and activate the horns for a three (3) second period to ensure the horns are functioning properly.

### 10.5 Test Quick Connect Coupler

1. Allow the air compressor to refill the tank, if needed.
2. Attach the supplied INF-1 inflator kit to the quick connect coupler and verify adequate air pressure is available
3. Test fill tires on vehicle, bicycle, etc.
4. Test air blow gun.

END OF SECTION



## 11 General Operation

### 11.1 Compressor Operation

**WARNING:** NEVER operate the air compressor above its MAXIMUM PRESSURE RATING (see label on body). Operation exceeding maximum pressure will damage the compressor and potentially cause air system failure.

1. Kleinn’s oil-less compressor is equipped with an automatic thermal overload protection circuit designed to protect the air compressor from overheating and causing permanent damage.
2. Automatic thermal overload protector will reset after 30 minutes.
3. To prevent discharge of the vehicle’s battery, and for best performance, keep the vehicle’s engine running while using the air compressor for any prolonged use (i.e., filling tires, using air tools, etc.).

### 11.2 Horn Operation

1. Allow the air compressor to run until it shuts off automatically, (i.e., air tank is full) or for at least one minute between horn activations.
2. Press the horn button to activate the horns
3. Horn sound/loudness will taper as the air tank pressure decreases.
4. Horns should sound for 3-7 seconds depending on kit and tank size.

**WARNING:** NEVER operate train horns with ears near trumpets or in an enclosed space without [hearing protection](#) (i.e., > Ear Plugs/Muffs) for all persons closer than 100 feet from vehicle. Never operate train horns outdoors when persons are near vehicle without hearing protection.

END OF SECTION

## 12 Routine Maintenance

Perform following maintenance at least once during recommended intervals:

1. Yearly, or every 12,000 miles, verify all mounting fasteners are properly torqued. Applying witness

marks across fasteners and mounting parts is good practice to quickly ensure fasteners have not moved.

2. Yearly, or every 12,000 miles, **inspect OE wiring, tubing, cables, etc.** where kit parts may touch to **verify no abrasion or rubbing.**
3. Yearly, or every 12,000 miles, remove all road grime and mud from the mounting brackets and kit parts using clean water from a garden hose. Pay special attention to corners where dirt may collect. Touch up all paint chips using automotive grade enamel in either spray or brush form.

**NOTE:** Do this more frequently if traveling regularly off-road, or in winter climates with road salts. High-pressure washers may damage part finishes and must be used with care.

4. Yearly, or every 12,000 miles, check electrical connections, wires, and air fittings for abrasion, corrosion, or other damage. Replace damaged components.

**NOTE:** if system runs continuously or turns on unexpectedly, leaks or a poor electrical connection may be present.

5. Monthly, or every 10 hours of compressor run time, drain moisture from the air tank using the drain valve installed at the bottom of the tank.

**WARNING:** Failure to regularly drain the air tank may result in corrosion inside the tank and possible failure in the tank or air tubing, causing injury.

6. Yearly, or every 12,000 miles, clean or replace the air compressor air filter element. Replacement frequency depends on operating frequency and conditions of environment (i.e., daily use requires more frequent changes). Order replacement filters at [Kleinn.com](http://Kleinn.com).

**NOTE:** NEVER lubricate or add liquids to the compressor.

END OF SECTION



## 13 Warranty Information

Thank you for purchasing our Air Horn Kit. Shall you experience any unexpected problems during installation or have problems with any part at any time please contact Kleinn support.

### **KLEINN MANUFACTURER LIMITED DEFECT WARRANTY:**

Kleinn Automotive Air Horns warrants this product to the end-user, when properly installed and under normal conditions of use, to be free from defects in workmanship and materials for a period of one year from the provided date of purchase, to the original purchaser of the product. This warranty does not cover abuse, operation in a manner inconsistent with the product's design, or damage resulting from exposure to the elements. If the defect is considered "under warranty", Kleinn will, at its option, repair or replace the product free of charge to the original purchaser. Kleinn is not liable for any installation charges, loss or damage of any kind incurred in the replacement or repair of any warranted product.

END OF MANUAL

© Kleinn Air Horns 2021, All rights reserved.

PO Box 91278 Tucson, AZ 85752

Phone: (520) 579-1531

Web: <https://www.kleinn.com>